

Model R4045

SCISSOR LIFTS



MORE ECONOMIC

- Lower Total Cost of Ownership.

MORE PRODUCTIVE

- Boost efficiency with optional AGM batteries.
- Improved uptime.

MORE ACCESS

- Get into more places with compact dimensions and precise positioning ability for both drive and lift.

SMART DESIGN

- Improved, reliable and simple active pothole protection.
- Platform and service trays are made of steel for more resistance.
- Wide-opening and stable steel doors provide easy access to batteries and components.

Standard Features

- 0.91 m roll-out deck extension
- Fold down handrails
- Half swing gate
- Removable platform control box
- Lanyard attach points
- Full proportional drive joystick control with integral thumb steer switch
- Proportional lift/lower speed control
- Joystick enable for lift and drive
- Zero load sensing system
- 4 x 12V 150 A/hr deep cycle batteries
- Automatic positive traction
- Programmable "Personality" settings
- On-board self-diagnostic testing
- Swingout steel battery/electrical compartments doors
- 27 amp automatic battery charger
- Front wheel hydraulic drive motors
- Dual wheel automatic brakes (on rear wheels)
- Emergency brake release
- Active pothole protection system
- AC cable to platform
- Battery charge level indicator
- Variable tilt indicator
- Hourmeter
- Lubrication free scissor arm bushings
- Scissor maintenance prop
- Manual descent
- Horn
- Non-marking solid tyres (406 x 127)
- Lifting and tie down points
- Slope alarm and light
- Fork lift pockets

Standard Specifications

- | | |
|-------------------------------|-------------------------|
| • Tyres (Non-Marking Solid) | 406 x 127 |
| • Brakes | Hydraulic |
| • Drive (Nominal) | Hydraulic |
| • Batteries | 4x 12V 150A/hr |
| • Charger (120/240V -50/60Hz) | 24v @27Amp Automatic |
| • Pump Motor | 4.5kW |
| • Hydraulic System | 30L |
| • Hydraulic Reservoir Pump | Fixed displacement gear |

Accessories & Options



- 150A/hr maintenance free AGM batteries in lieu of standard
- 185AH, 12V Batteries Flooded/Lead-acid
- Mobile control*
- All motion alarm
- Pipe racks
- Amber strobe light
- Anti-vandalism package
- Multi-display indicator (MDI)
- ClearSky Locate
- ClearSky CAN
- Drive motor covers
- Extension deployment handles
- Synthetic biodegradable hydraulic oil
- Hydraulic oil (Mobil 424)
- Hydraulic oil (Cold weather)
- Panel carrier
- Platform work lights
- SkySense level 1
- SkySense level 2
- Operator access control

* Pending CE certification

Model R4045

SCISSOR LIFTS

Performance

• Working Height	13.96 m
• Platform Height - Elevated	11.96 m
A. Stowed Height	2.54 m
B. Platform Height - Lowered	1.4 m
C. Platform Railing Height	1.13 m
D. Stowed Height (Rails Folded)	1.89 m
E. Platform Size Inside (W x L)	1.05 m x 2.43 m
F. Deck Extension	0.91 m
G. Overall Width	1.14 m
H. Overall Length **	2.71 m
I. Wheelbase	2.03 m
J. Ground Clearance (centre of machine)	12.6 cm
• Platform Capacity - indoor	 350 kg
• Platform Capacity - outdoor	 250 kg
• Capacity on Deck Extension	113 kg
• Lift/Lower Time (no load)	68/41 sec.
• Maximum Drive Height	8.74 m
• Machine weight *	3,175 kg
• Maximum Ground Bearing Pressure	9.63 kg/cm ²
• Drive Speed - Lowered	3.22 km/h
• Drive Speed - Elevated	0.8 km/h
• Gradeability	25%
• Turning Radius - Inside	0.0 m
• Turning Radius - Outside	2.54 m



* Certain options or country standards may increase weight and/or dimensions.

** Incl ladder, excl ladder 2.56 m.

Dimensions

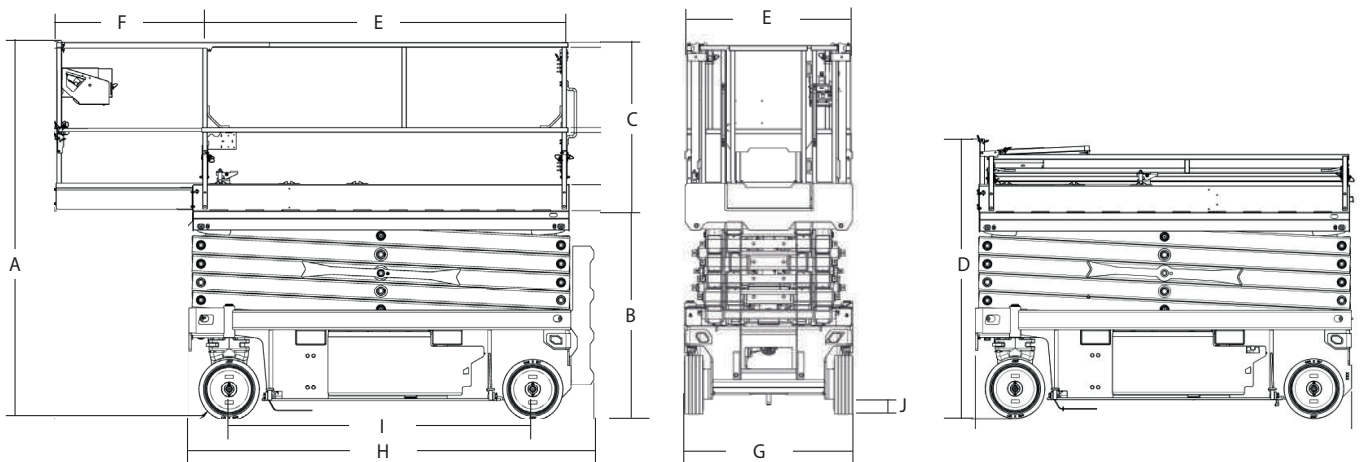

IMPORTANT

JLG is continually researching and developing products and reserves the right to make modifications without prior notice. All data in this document is indicative. Certain options or country standards will increase weight. Specifications may change to meet country standards or with the addition of optional equipment.

JLG EMEA BV

Polaris Avenue 63
2132 JH Hoofddorp
The Netherlands
Tel.: +31 (0)23 565 5665
www.jlg.com

Due to continuous product improvements, JLG Industries reserves the right to make specification and/or equipment changes without prior notification.

An Oshkosh Corporation Company